



US010319796B2

(12) **United States Patent**
Jang et al.

(10) **Patent No.:** **US 10,319,796 B2**
(45) **Date of Patent:** **Jun. 11, 2019**

(54) **ORGANIC LIGHT EMITTING DISPLAY DEVICE**

H01L 51/5209 (2013.01); *H01L 51/5225* (2013.01); *H01L 51/5275* (2013.01); *H01L 2251/5315* (2013.01)

(71) Applicant: **LG Display Co., Ltd.**, Seoul (KR)

(58) **Field of Classification Search**

None
See application file for complete search history.

(72) Inventors: **Jihyang Jang**, Gyeonggi-do (KR); **Sookang Kim**, Gyeonggi-do (KR); **Soyoung Jo**, Seoul (KR); **Wonho Koo**, Gyeonggi-do (KR); **Hyunsoo Lim**, Gyeonggi-do (KR); **Mingeun Choi**, Chungcheongnam-do (KR)

(56) **References Cited**

U.S. PATENT DOCUMENTS

9,142,793 B2 * 9/2015 Choi H01L 51/52
2004/0017152 A1 1/2004 Hashimoto et al.
(Continued)

(73) Assignee: **LG Display Co., Ltd.**, Seoul (KR)

(*) Notice: Subject to any disclaimer, the term of this patent is extended or adjusted under 35 U.S.C. 154(b) by 0 days.

FOREIGN PATENT DOCUMENTS

CN 203150551 U * 8/2013
CN 104659070 A 5/2015
(Continued)

(21) Appl. No.: **15/968,594**

(22) Filed: **May 1, 2018**

OTHER PUBLICATIONS

(65) **Prior Publication Data**

US 2018/0247987 A1 Aug. 30, 2018

Office Action dated Oct. 30, 2017 from the Taiwan Patent Office in related Taiwanese application No. 105130497 (partial English translation).

Related U.S. Application Data

(63) Continuation of application No. 15/271,450, filed on Sep. 21, 2016, now Pat. No. 9,978,819.

Primary Examiner — J. E. Schoenholtz

(74) *Attorney, Agent, or Firm* — Morgan, Lewis & Bockius LLP

(30) **Foreign Application Priority Data**

Sep. 23, 2015 (KR) 10-2015-0134419

(57) **ABSTRACT**

An organic light emitting display device includes an overcoating layer on a substrate; a first electrode on the overcoating layer; a bank layer on the overcoating layer and the first electrode, the bank layer including an opening through which the first electrode is exposed; a pattern layer having an island shape on the exposed portion of the first electrode; an organic emission layer on the first electrode and the pattern layer; and a second electrode on the organic emission layer.

(51) **Int. Cl.**

H01L 27/32 (2006.01)

H01L 51/52 (2006.01)

(52) **U.S. Cl.**

CPC *H01L 27/3246* (2013.01); *H01L 27/322* (2013.01); *H01L 27/326* (2013.01); *H01L 27/3258* (2013.01); *H01L 27/3272* (2013.01);

21 Claims, 13 Drawing Sheets

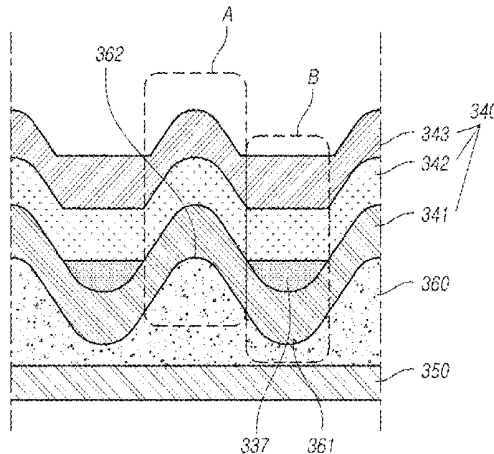

(56) **References Cited**

U.S. PATENT DOCUMENTS

2008/0122347 A1 5/2008 Lee
2014/0306200 A1 10/2014 Jinta et al.
2014/0354711 A1 12/2014 In et al.
2015/0145423 A1 5/2015 Lee et al.
2015/0155520 A1 6/2015 Kim et al.
2016/0268354 A1 9/2016 Xiong et al.
2017/0005286 A1* 1/2017 Yun H01L 51/5209

FOREIGN PATENT DOCUMENTS

JP 2004-127575 4/2004
JP 2015-109136 6/2015
KR 1020040010342 A 1/2004
KR 1020110122250 A 11/2011
KR 20150077279 A 7/2015
TW 201445535 A 12/2014
TW 201521004 A 6/2015
TW 201523962 A 6/2015

* cited by examiner

FIG. 1

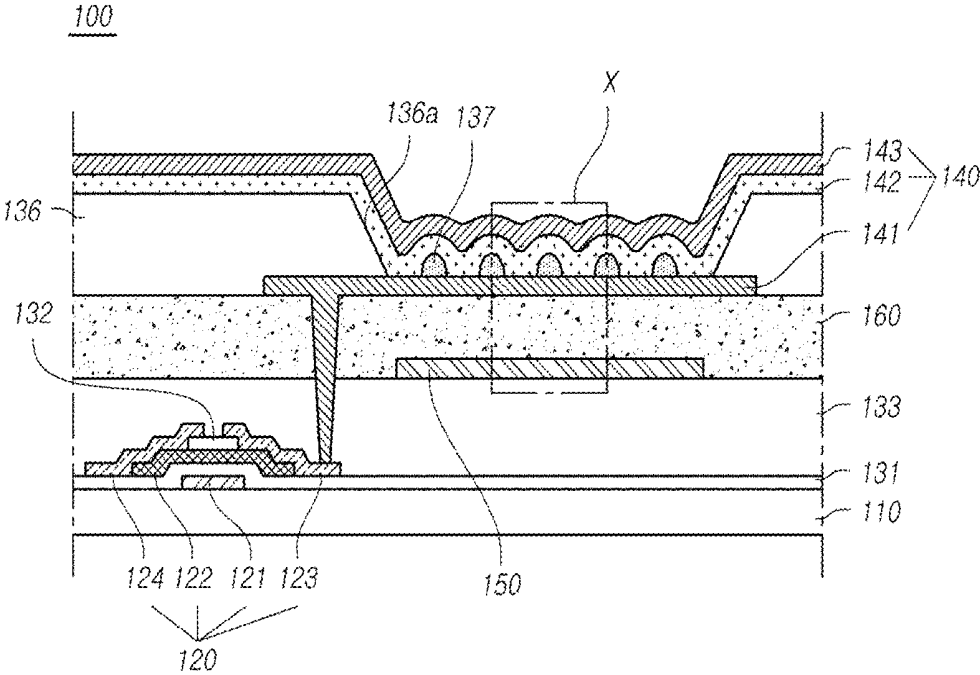

FIG. 2

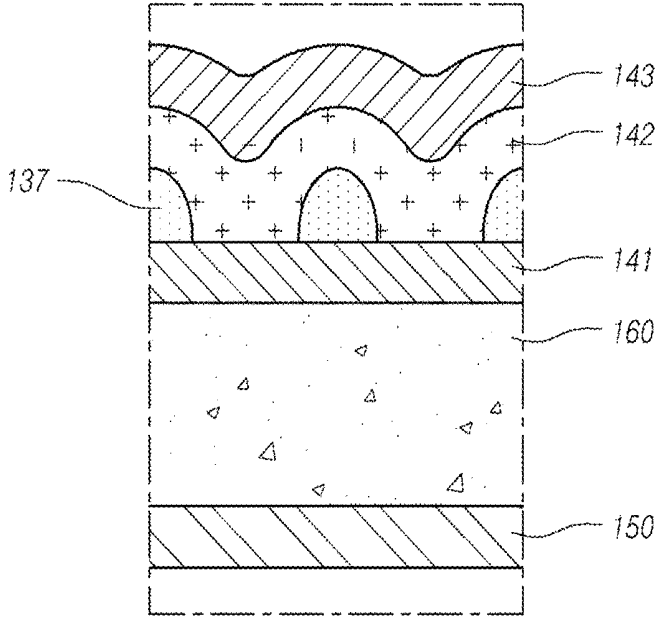

FIG. 3

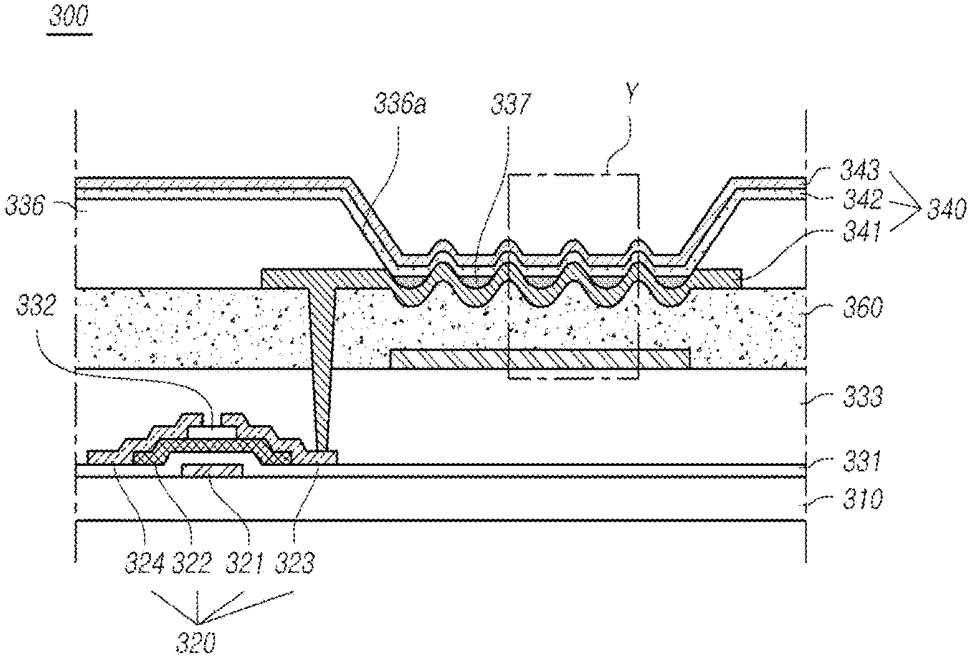

FIG. 4A

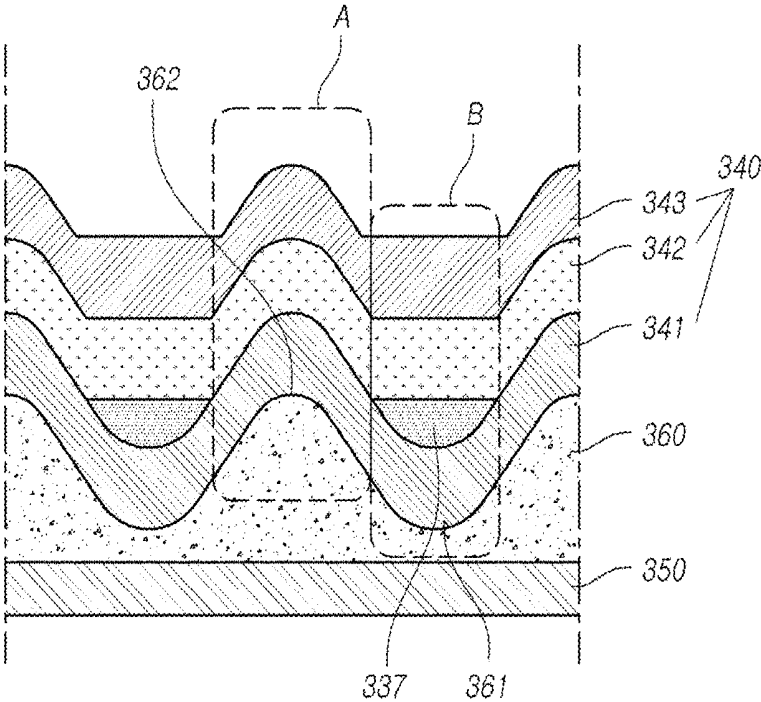

FIG. 4B

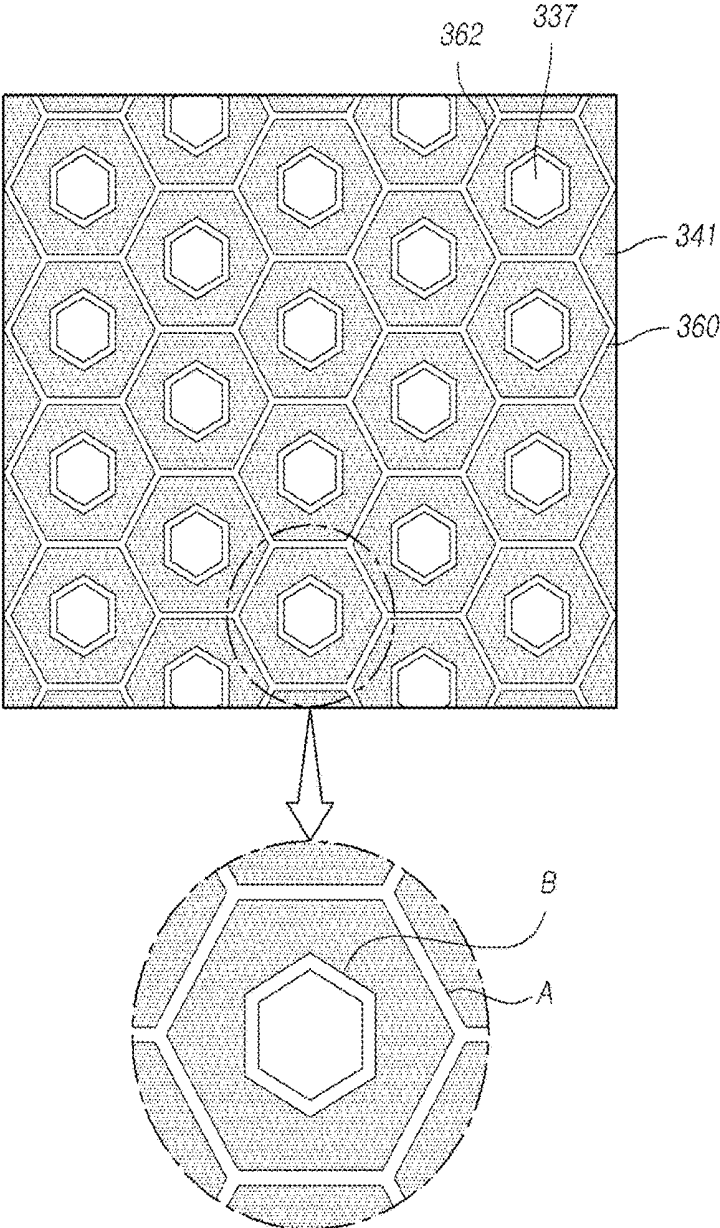

FIG. 5

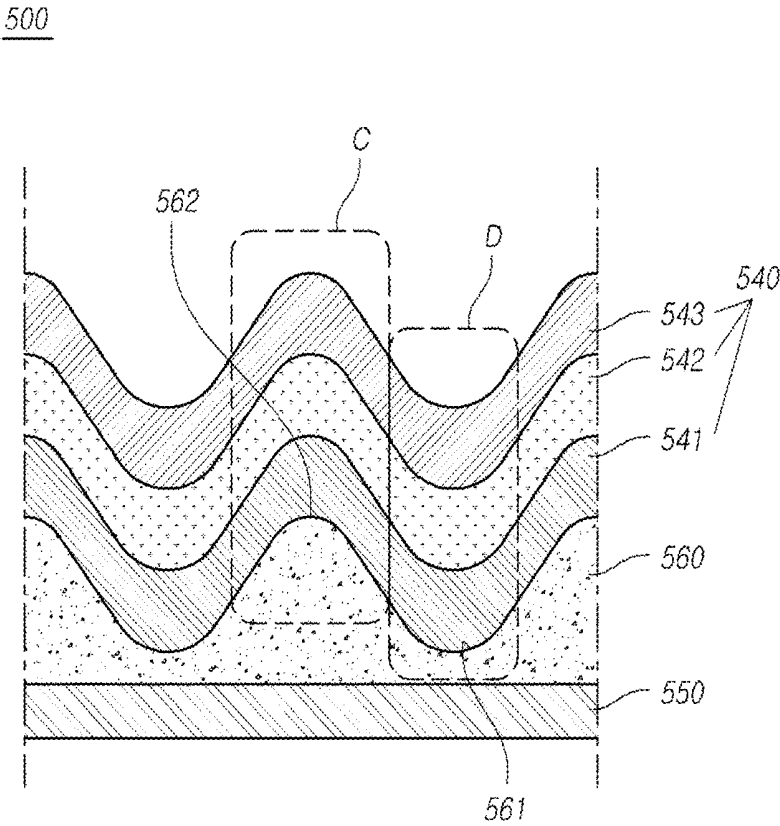

FIG. 6

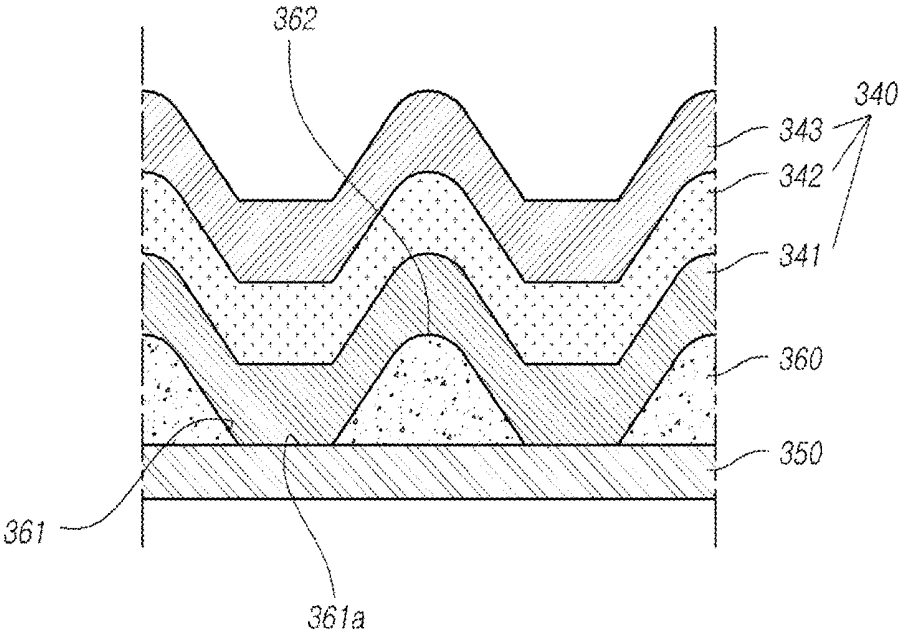

FIG. 7

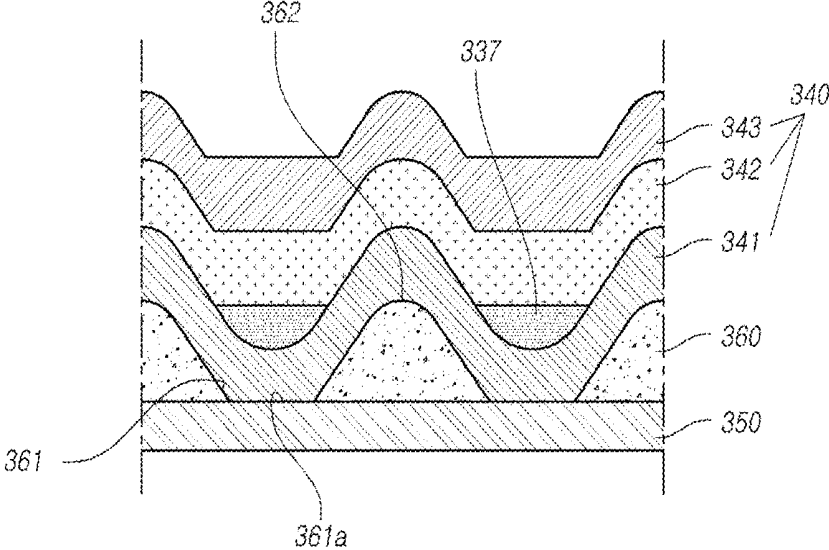

FIG. 8A

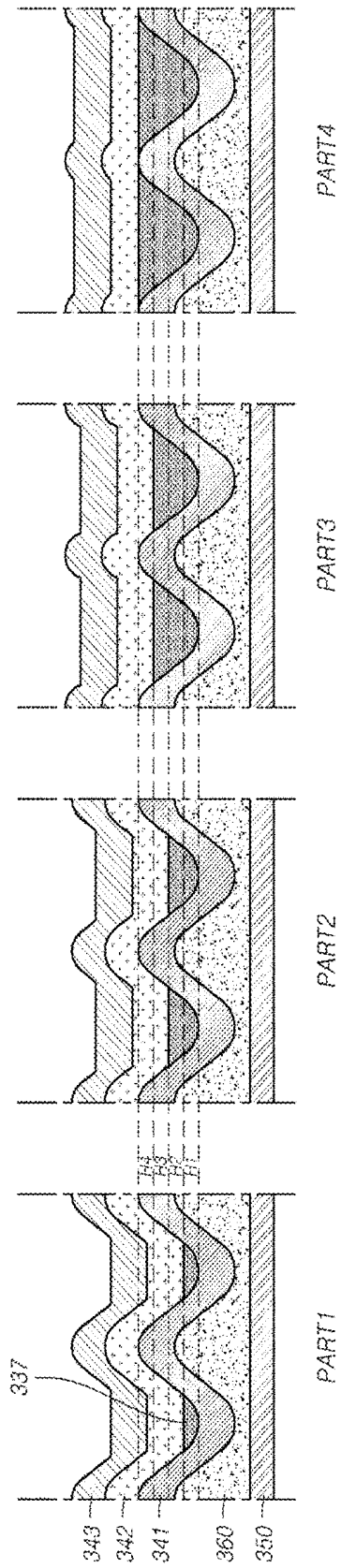

FIG. 8B

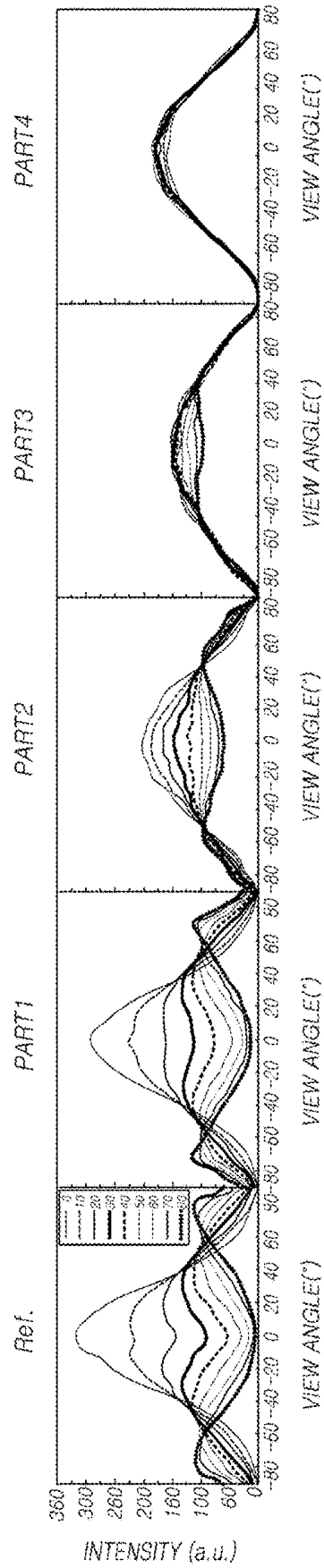

FIG. 8C

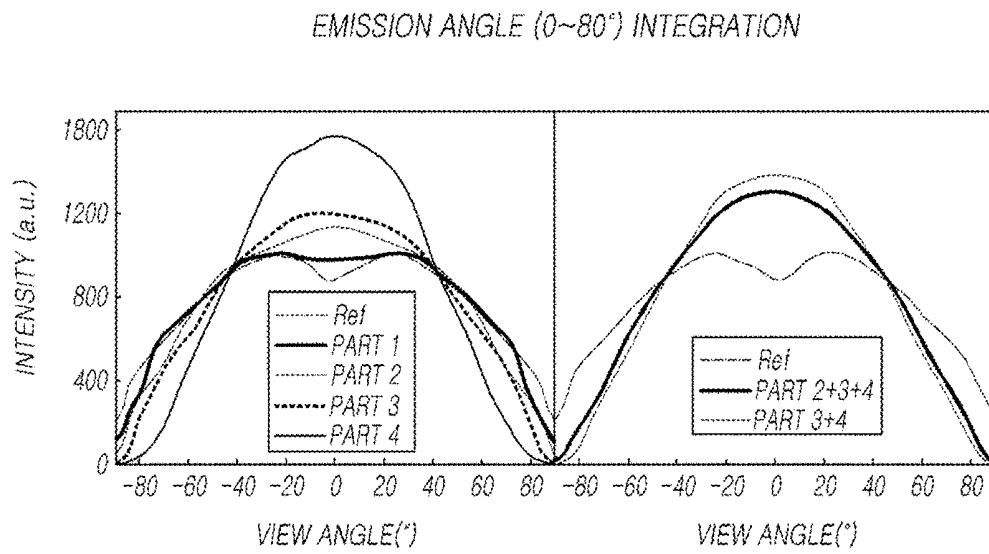

FIG. 9

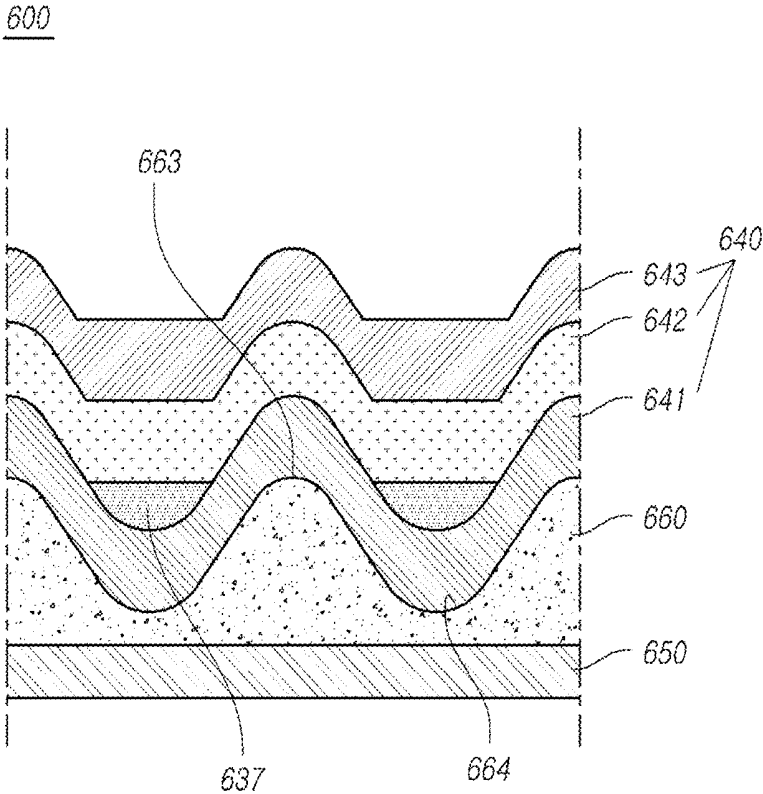
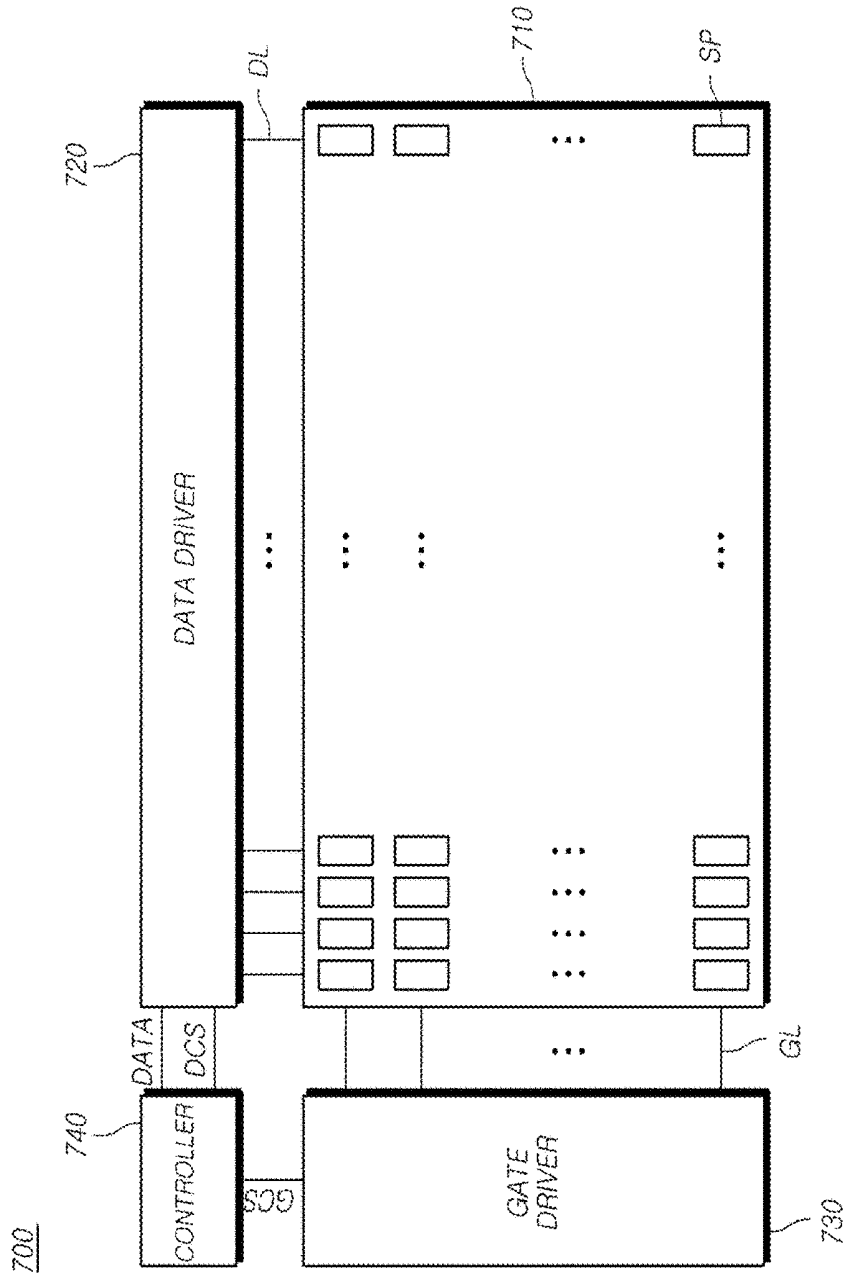

FIG. 10



ORGANIC LIGHT EMITTING DISPLAY DEVICE

CROSS-REFERENCE TO RELATED APPLICATIONS

This application is a Continuation of U.S. patent application Ser. No. 15/271,450, filed Sep. 21, 2016, which claims priority from Korean Patent Application No. 10-2015-0134419, filed on Sep. 23, 2015, which are both hereby incorporated by reference for all purposes as if fully set forth herein.

BACKGROUND

Field of the Invention

The present invention relates to an organic light emitting display device that displays an image.

Description of the Related Art

An organic light emitting display device, which has recently attracted a lot of attention as a display device, uses a self-emitting organic light emitting diode (OLED). Thus, the organic light emitting display device has advantages of a high response speed, increased contrast ratio, increased luminous efficiency, high brightness, and wide view angle.

Light emitted from an organic emission layer of the organic light emitting display device is output to the outside of the organic light emitting display device through various elements in the organic light emitting display device. However, a portion of the light emitted from the organic emission layer may not be output to the outside of the organic light emitting display device but may be confined in the organic light emitting display device, thereby causing problems with the light extraction efficiency of the organic light emitting display device. To improve the light extraction efficiency of the organic light emitting display device, a method of attaching a micro lens array (MLA) to an outer surface of a substrate of the organic light emitting display device has been used.

SUMMARY

Accordingly, the present invention is directed to an organic light emitting display device that substantially obviates one or more of the problems due to limitations and disadvantages of the related art.

An object of the present invention is to provide an organic light emitting display device that can improve external luminous efficiency and reduce power consumption.

Additional features and advantages of the invention will be set forth in the description that follows, and in part will be apparent from the description, or may be learned by practice of the invention. The objectives and other advantages of the invention will be realized and attained by the structure particularly pointed out in the written description and claims hereof as well as the appended drawings.

To achieve these and other advantages and in accordance with the purpose of the present invention, as embodied and broadly described, an organic light emitting display device comprises an overcoating layer on a substrate; a first electrode on the overcoating layer; a bank layer on the overcoating layer and the first electrode, the bank layer including an opening through which the first electrode is exposed; a pattern layer having an island shape on the exposed portion

of the first electrode; an organic emission layer on the first electrode and the pattern layer; and a second electrode on the organic emission layer.

It is to be understood that both the foregoing general description and the following detailed description are exemplary and explanatory and are intended to provide further explanation of the invention as claimed.

BRIEF DESCRIPTION OF THE DRAWINGS

The accompanying drawings, which are included to provide a further understanding of the invention and are incorporated in and constitute a part of this specification, illustrate embodiments of the invention and together with the description serve to explain the principles of the invention. In the drawings:

FIG. 1 is a cross-sectional view of an organic light emitting display device according to an example embodiment;

FIG. 2 is an enlarged cross-sectional view of an area X of FIG. 1;

FIG. 3 is a cross-sectional view of an organic light emitting display device according to another example embodiment;

FIG. 4A is an enlarged cross-sectional view of an area Y of FIG. 3;

FIG. 4B is a partial plane view of an overcoating layer, a first electrode, and a pattern layer in the area Y of FIG. 3;

FIG. 5 is a partial cross-sectional view of an organic light emitting display device according to a comparative example;

FIG. 6 is a cross-sectional view illustrating an example of an overcoating layer in a general organic light emitting display device;

FIG. 7 is a cross-sectional view illustrating a modification example of an overcoating layer in the organic light emitting display device according to another example embodiment;

FIG. 8A through FIG. 8C are diagrams comparatively illustrating an external light extraction efficiency and a distribution (view angle) depending on a location of an emission surface of an organic emission layer (adjustment of an effective emission area) with an adjusted thickness of a pattern layer disposed on a concave portion of an overcoating layer;

FIG. 9 is a cross-sectional view provided to explain an organic light emitting display device including an overcoating layer having a plurality of convex portions according to yet another example embodiment; and

FIG. 10 is a schematic system configuration view of an organic light emitting display device according to the present example embodiments.

DETAILED DESCRIPTION

Hereinafter, embodiments of the present invention will be described in detail with reference to the accompanying drawings. When reference numerals refer to components of each drawing, although the same components are illustrated in different drawings, the same components are referred to by the same reference numerals as possible. Further, if it is considered that description of related known configuration or function may cloud the gist of the present invention, the description thereof will be omitted.

Further, in describing components of the present invention, terms such as first, second, A, B, (a), and (b) can be used. These terms are used only to differentiate the components from other components. Therefore, the nature, order, sequence, or number of the corresponding components is not

limited by these terms. It is to be understood that when one element is referred to as being “connected to” or “coupled to” another element, it may be directly connected to or directly coupled to another element, connected to or coupled to another element, having still another element “intervening” therebetween, or “connected to” or “coupled to” another element via still another element.

FIG. 1 is a cross-sectional view of an organic light emitting display device according to an example embodiment. FIG. 2 is an enlarged cross-sectional view of an area X of FIG. 1.

As shown in FIG. 1 and FIG. 2, an organic light emitting display device 100 may include a substrate 110, a thin-film transistor 120, a color filter 150, an overcoating layer 160, a pattern layer 137, and an organic light emitting diode 140.

The thin-film transistor 120, which includes a gate electrode 121, an active layer 122, a source electrode 123, and a drain electrode 124, is on the substrate 110. Specifically, the gate electrode 121 is on the substrate 110, and a gate insulation layer 131 configured to insulate the gate electrode 121 and the active layer 122 is on the gate electrode 121 and the substrate 110. Further, the active layer 122 is disposed on the gate insulation layer 131, and an etch stopper 132 is on the active layer 122. Furthermore, the source electrode 123 and the drain electrode 124 are on the active layer 122 and the etch stopper 132. The source electrode 123 and the drain electrode 124 are electrically connected to the active layer 122 to be in contact with the active layer 122 and on a portion of the etch stopper 132. The etch stopper 132 may be omitted.

In FIGS. 1 and 2, from among various thin-film transistors that can be included in the organic light emitting display device 100, only a driving thin-film transistor has been illustrated for convenience in explanation. Further, in the thin-film transistor 120 may have an inverted staggered structure or a bottom-gate structure in which the gate electrode 121 is located across from the source electrode 123 and the drain electrode 124 with the active layer 122 interposed therebetween. However, a thin-film transistor may be used having a coplanar structure or a top-gate structure in which the gate electrode 121 is located on the same side of the active layer 122 as the source electrode 123 and the drain electrode 124.

In FIGS. 1 and 2, a passivation layer 133 is on the thin-film transistor 120, and the color filter 150 is on the passivation layer 133. The color filter 150 is configured to convert the color of a light emitted from an organic emission layer 142, and may be one of a red color filter, a green color filter, and a blue color filter.

The overcoating layer 160 is on the color filter 150 and the passivation layer 133. The overcoating layer 160 includes a flat top surface. The organic light emitting diode 140 (which includes a first electrode 141, the organic emission layer 142, and a second electrode 143), a bank layer 136, and a pattern layer 137 are on the overcoating layer 160.

The bank layer 136 is on the overcoating layer 160 and the first electrode 141, and includes an opening 136a through which the first electrode 141 is exposed. The bank layer 136 is configured to distinguish adjacent pixel (or subpixel) areas, and may be between the adjacent pixel (or subpixel) areas.

The pattern layer 137 is on the first electrode 150. The pattern layer 137 has an island shape on the first electrode 150 exposed through the opening 136a of the bank layer 136.

The pattern layer 137 may include the same material as the bank layer 136. In terms of processes, after the flat

overcoating layer 160 is formed, the first electrode 141 is formed on the overcoating layer 160. An original material of the bank layer 136 and the pattern layer 137 is coated on the overcoating layer 160 and the entire surface of the first electrode 141. Then, an exposure and development process is performed using a mask corresponding to the opening 136a of the bank layer 136 and the pattern layer 137. Herein, a location corresponding to the pattern layer 137 is exposed and developed with a smaller amount of light than a related art process. Thus, the bank layer 136 and the pattern layer 137 can be formed of the same material as the bank layer 136 at the same time without a specially added process or mask.

The organic emission layer 142 is disposed on the first electrode 141 and the pattern layer 137, and the second electrode 143 configured to supply one of an electron or a hole to the organic emission layer 142 is on the organic emission layer 142.

In the opening 136a of the bank layer 136, the first electrode 141 on the overcoating layer 160 has a shape according to the surface topology of the overcoating layer 160. That is, in the opening 136a of the bank layer 136, the first electrode 141 on the overcoating layer 160 has a flat shape including flat bottom and top surfaces. The organic emission layer 142 and the second electrode 143 are disposed along a shape of the top surface of the first electrode 141 according to the surface morphology of the overcoating layer 160 and a shape of a top surface of the pattern layer 137. Thus, the organic emission layer 142 and the second electrode 143 have non-flat top and bottom surfaces. Therefore, the first electrode 141 has a flat shape, whereas the organic emission layer 142 and the second electrode 143 have a convex shape on the pattern layer 137. As a result, in the organic light emitting display device 100, the pattern layer 137 is on the first electrode 141 and the organic emission layer 142 and the second electrode 143 have bends. Thus, the organic light emitting display device 100 includes a micro lens array (MLA) structure.

In the organic light emitting display device 100, a concave portion or a convex portion is not formed on the overcoating layer 160 and the bank layer 136, and the pattern layer 137 are formed at the same time. Thus, it is possible to form a micro lens array structure without an additional process. Because the micro lens array structure is formed using the pattern layer 137, the external light extraction efficiency can be improved.

FIG. 3 is a cross-sectional view of an organic light emitting display device according to another example embodiment. FIG. 4A is an enlarged cross-sectional view of an area Y of FIG. 3. FIG. 4B is a partial plane view of an overcoating layer, a first electrode, and a pattern layer in the area Y of FIG. 3.

With reference to FIG. 3 and FIG. 4A, an organic light emitting display device 300 includes a substrate 310, a thin-film transistor 320, a color filter 350, an overcoating layer 360, a pattern layer 337, and an organic light emitting diode 340.

The organic light emitting display device 300 illustrated in FIG. 3 and FIG. 4A are a bottom-emission organic light emitting display device. However, the organic light emitting display device 300 may be a top-emission organic light emitting display device in which the color filter 350 is located across from the substrate 310.

The thin-film transistor 320 including a gate electrode 321, an active layer 322, a source electrode 323, and a drain electrode 324 is disposed on the substrate 310. Specifically, the gate electrode 321 is on the substrate 310, and a gate insulation layer 331 configured to insulate the gate electrode

321 and the active layer **322** is disposed on the gate electrode **321** and the substrate **310**. Further, the active layer **322** is on the gate insulation layer **331**, and an etch stopper **332** is disposed on the active layer **322**. Furthermore, the source electrode **323** and the drain electrode **324** are on the active layer **322** and the etch stopper **332**. The source electrode **323** and the drain electrode **324** are electrically connected to the active layer **322** to be in contact with the active layer **322** and on a portion of the etch stopper **332**. The etch stopper **332** may be omitted.

A passivation layer **333** is disposed on the thin-film transistor **320**, and the color filter **350** is disposed on the passivation layer **333**.

FIG. 4A illustrates that the passivation layer **333** flattens an upper part of the thin-film transistor **320**. However, the passivation layer **333** may not flatten the upper part of the thin-film transistor **320**, but may be disposed according to the surface morphology of elements located under the passivation layer **333**.

The color filter **350** is configured to convert a color of the light emitted from an organic emission layer **342**, and may be one of a red color filter, a green color filter, and a blue color filter. The color filter **350** is at a location corresponding to an emission area on the passivation layer **333**. Herein, the emission area refers to an area where a light is emitted from the organic emission layer **342** by the first electrode **341** and the second electrode **343**. The color filter **350** is at a location corresponding to the emission area, which means that the color filter **350** is disposed to suppress occurrence of blurring phenomenon or ghost phenomenon caused by mixing of lights emitted from adjacent emission areas.

For example, the color filter **350** may overlap the emission area. Herein, a location and a size of the color filter **350** may be determined by various factors including a size and a location of the emission area, a distance between the color filter **350** and the first electrode **341**, a distance between the color filter **350** and a concave portion **361** (or a convex portion) of the overcoating layer **360**, and a distance between emission areas.

The overcoating layer **360** is disposed on the color filter **350** and the passivation layer **333**. FIG. 4A illustrates that the passivation layer **333** (see FIG. 3) is included in the organic light emitting display device **300**. However, the passivation layer **333** may be omitted, and the overcoating layer **360** may be directly on the thin-film transistor **320**. Further, FIG. 4A illustrates that the color filter **350** is on the passivation layer **333** (see FIG. 3), but the present invention is not limited thereto. The color filter **350** may be provided at any location between the overcoating layer **360** and the substrate **310**.

The overcoating layer **360** includes a plurality of concave portions **361** to overlap the color filter **350** and a first connection portion **362** that connects the concave portions **361** adjacent to each other. FIG. 4A is a cross-sectional view of the plurality of concave portions **361** having a hexagonal shape. The first connection portion **362** is a higher portion between the concave portions **361** adjacent to each other. The overcoating layer **360** functions as a flattening layer in an area where the plurality of concave portions **361** is disposed.

As illustrated in FIG. 4B, each of the plurality of concave portions **361** (see FIG. 4A) and the first connection portion **362** may have an overall hexagonal shape in a plane view, but is not limited thereto and may have various shapes such as an overall hemispherical shape, semi-elliptical shape or square shape. The plurality of concave portions **361** may be disposed in a hexagonal honeycomb structure in a plane

view. In other words, a hexagonal concave portion **361** shares one side with another adjacent concave portion **361** to be formed as one body having a hexagonal honeycomb structure.

The organic light emitting diode **340** including a first electrode **341**, the organic emission layer **342**, and a second electrode **343**, a bank layer **336**, and a pattern layer **337** are disposed on the overcoating layer **360**. Herein, although not illustrated, a second insulating passivation layer (not illustrated) configured to suppress the spread of outgassing from the overcoating layer **360** to the organic light emitting diode **340** to reduce the lifetime of the organic light emitting diode, and having a shape according to the morphology of the concave portions **361** of the overcoating layer **360** and a refractive index similar to that of the first electrode **341** may be further disposed between the overcoating layer **360** and the first electrode **341**.

Specifically, the first electrode **341** configured to supply one of an electron or a hole to the organic emission layer **342** is disposed on a portion of the overcoating layer **360**. The first electrode **341** may be a positive electrode, a pixel electrode, or an anode in a normal OLED, or may be a negative electrode, a pixel electrode, or a cathode in an inverted OLED.

The first electrode **341** may be connected to the source electrode **323** of the thin-film transistor **320** through a contact hole formed in the overcoating layer **360**. Here, the first electrode **341** is described as being connected to the source electrode **323** on the assumption that the thin-film transistor **320** is an N-type thin-film transistor. However, if the thin-film transistor **320** is a P-type thin-film transistor, the first electrode **341** may be connected to the drain electrode **324**. The first electrode **341** may be electrically connected to the organic emission layer **342** directly contacting the organic emission layer **342** or contacting the organic emission layer **342** with a conductive material interposed therebetween.

The first electrode **341** is disposed in a shape according to the surface morphology of the overcoating layer **360**. Therefore, the first electrode **341** having a concave morphology on the concave portion **361** of the overcoating layer **360**.

The bank layer **336** is on the overcoating layer **360** and the first electrode **341** and includes an opening **336a** through which the first electrode **341** is exposed. The bank layer **336** is configured to distinguish adjacent pixel (or subpixel) areas, and may be disposed between the adjacent pixel (or subpixel) areas. The concave portions **361** and the first connection portion **362** of the overcoating layer **360** are disposed to overlap the opening **336a** of the bank layer **336**. As described above, the concave portions **361** and the first connection portion **362** of the overcoating layer **360** overlapping the color filter **350**. Thus, the concave portions **361** and the first connection portion **362** of the overcoating layer **360** overlap the color filter **350** thereunder and also overlap the opening **336a** of the bank layer **336** thereon. The pattern layer **337** is on the first electrode **341**. The pattern layer **337** has an island shape on the first electrode **341** exposed through the opening **336a** of the bank layer **336**. That is, the pattern layer **337** on the first electrode **341** partially fills recessed areas of the plurality of concave portions **361** of the overcoating layer **360**. The pattern layer **337** may be located in all of the plurality concave portions as illustrated in FIG. 4B, but is not limited thereto. The pattern layer **337** may be located in some of the plurality of concave portions. The pattern layer **337** may lessen bends of a surface on which the organic light emitting diode **340** is disposed.

The pattern layer 337 may include the same material as the bank layer 336. In terms of processes, after the overcoating layer 360 including the concave portions 361 and the first connection portion 362 is formed, the first electrode 341 is formed on the overcoating layer 360. An original material of the bank layer 336 and the pattern layer 337 is coated on the overcoating layer 360 and the entire surface of the first electrode 341. Then, an exposure and development process is performed using a mask corresponding to the opening 336a of the bank layer 336 and the pattern layer 337. Herein, a location corresponding to the pattern layer 337 is exposed and developed with a smaller amount of light than a conventional process. Thus, the bank layer 336 and the pattern layer 337 can be formed of the same material as the bank layer 336 at the same time without a specially added process or mask.

The organic emission layer 342 is disposed on the first electrode 341 and the pattern layer 337, and the second electrode 343 configured to supply one of an electron or a hole to the organic emission layer 342 is disposed on the organic emission layer 342. The organic emission layer 342 is disposed in a structure (e.g., tandem white) in which a plurality of organic emission layers is laminated to emit a white light. The organic emission layer 342 includes a first organic emission layer configured to emit a blue light and a second organic emission layer disposed on the first organic emission layer and configured to emit a light of a color which turns to white when mixed with blue. The second organic emission layer may be, for example, an organic emission layer that emits a yellow-green light. Meanwhile, the organic emission layer 342 may include only an organic emission layer that emits one of a blue light, a red light, and a green light. In this case, the color filter 350 may not be provided. The second electrode 343 may be a negative electrode, a common electrode, or a cathode in a normal OLED, or may be a positive electrode, a common electrode, or an anode in an inverted OLED.

The organic emission layer 342 and the second electrode 343 are disposed along a shape of the top surface of the first electrode 341 according to the surface morphology of the overcoating layer 360 and a shape of a top surface of the pattern layer 337 disposed on the first electrode 341 and partially filling the recessed areas of the plurality of concave portions 361 of the overcoating layer 360, thereby having non-flat top and bottom surfaces. For example, if the organic emission layer 342 and the second electrode 343 are disposed by deposition, the organic emission layer 342 and the second electrode 343 are disposed according to the morphology of the top surfaces of the first electrode 341 and the pattern layer 337.

With reference to FIG. 4A, a thickness of the organic emission layer 342 between the concave portion 361 and the first connection portion 362 of the overcoating layer 360 may be less than a thickness of the organic emission layer 342 at the bottom of the concave portion 361 or the top of the first connection portion 362 of the overcoating layer 360. Particularly, the organic emission layer 342 may have the least thickness at a location where the organic emission layer 342 has the highest slope between the concave portion 361 and the first connection portion 362 of the overcoating layer 360.

For example, if the organic emission layer 342 is formed by deposition, the organic emission layer 342 deposited in a direction perpendicular to the substrate 310 has the same thickness. However, the organic emission layer 342 has a shape according to the morphology of the overcoating layer 360. Thus, actually, the organic emission layer 342 has the

least thickness for current drive between the first electrode 341 and the second electrode 342 at a location where the organic emission layer 342 has the highest slope, and has the greatest thickness at a location where the organic emission layer 342 has the lowest slope, i.e., at the bottom or the top.

In terms of an emission amount of the organic emission layer 342 depending on a thickness of the organic emission layer 342, an emission amount per unit area of the organic emission layer 342 between the concave portion 361 and the first connection portion 362 of the overcoating layer 360 may be greater than an emission amount per unit area of the organic emission layer 342 at the bottom of the concave portion 361 or the top of the first connection portion 362. Particularly, the organic emission layer 342 may have the greatest emission amount at a location where the organic emission layer 342 has the highest slope between the concave portion 361 and the first connection portion 362 of the overcoating layer 360.

FIG. 5 is a partial cross-sectional view of an organic light emitting display device according to a comparative example.

As shown in FIG. 5, an organic light emitting display device 500 according to the comparative example may include a color filter 550 and an overcoating layer 560 having concave portions 561 and a first connection portion 562. Further, the organic light emitting display device 500 includes an organic light emitting diode 540 including a first electrode 541, an organic emission layer 542, and a second electrode 543 disposed in sequence on the overcoating layer 560. The organic light emitting display device 500 according to the comparative example does not include the pattern layer 337 included in the organic light emitting display device 300 according to another example embodiment, and the first electrode 541, the organic emission layer 542, and the second electrode 543 have a shape according to the surface topology of the overcoating layer 560.

If the organic light emitting diode 540 has a micro lens array structure for improving external light extraction efficiency, concave bends are formed on a surface of the organic light emitting diode 540 by the concave portions 561 of the overcoating layer 560 due to characteristics of the pattern as illustrated in FIG. 5. As the slope is increased, a thickness of the organic emission layer 542 between the first electrode 541 and the second electrode 543 is decreased so that an effective emission area C where an electric field is locally concentrated, i.e., an area between the concave portion 561 and the first connection portion 562 of the overcoating layer 560, is generated. When the organic light emitting diode 540 is driven, an electric field is locally concentrated and a main current path is formed in the effective emission area, so that emission mainly occurs in the effective emission area. However, the concave portion 561 of the overcoating layer 560 is a non-effective emission area D, and light is hardly extracted from the non-effective emission area D. Although the non-effective emission area D consumes power, light is hardly extracted from the non-effective emission area D. Thus, the external light extraction efficiency is decreased.

Further, the bends of the concave portions 561 of the overcoating layer 560 mainly reflect an external light, thereby increasing reflectivity.

As illustrated in FIG. 4A and FIG. 4B, an area A where the pattern layer 337 is not disposed on the first electrode 341 exposed through the opening 336a of the bank layer 336 corresponds to an effective emission area which emits a light because the pattern layer 337 is not disposed between the first electrode 341 and the organic emission layer 342 and the second electrode 343. An area B where the pattern layer 337 is disposed on the first electrode 341 exposed through

the opening 336a of the bank layer 336 corresponds to a non-effective emission area, which does not emit a light because the pattern layer 337 is disposed between the first electrode 341 and the organic emission layer 342 and the second electrode 343.

In the organic light emitting display device 300 according to another example embodiment, the organic emission layer 342 has a non-uniform thickness due to the bends of the surface of the organic light emitting diode 340 caused by the bends of the concave portions 361 of the overcoating layer 360 and a current applied is concentrated in an area having a high slope so that a light is emitted from the effective emission area A only. However, in the non-effective emission area B, the pattern layer 337 is disposed between the first electrode 341 and the organic emission layer 342 and the second electrode 343, so that a light cannot be emitted. Therefore, it is possible to minimize or suppress most of the light from being confined in the organic light emitting diode 340 without a contribution to improvement of light extraction efficiency in a non-effective emission area D as illustrated in FIG. 5. Further, it is possible to minimize or suppress the light confined in the organic light emitting diode 340 from remaining as light leakage components in the non-effective emission area D as illustrated in FIG. 5. Accordingly, the external light extraction efficiency of the organic light emitting diode 340 can be maximized.

In the organic light emitting display device 300 according to another example embodiment, the pattern layer 337 disposed on the concave portion 561 of the overcoating layer 560 lessens bends of the overcoating layer 560. Thus, an external light reflectivity can be decreased.

Table 1 lists a measurement result of a driving voltage V, a current density J, a luminous efficiency cd/A, and an external quantum efficiency EQE of the organic light emitting display device 300 according to another example embodiment illustrated in FIG. 3 through FIG. 4B and the organic light emitting display device 500 according to the comparative example illustrated in FIG. 5. In Table 1, the external quantum efficiency EQE can be defined by multiplying internal quantum efficiency IQE and a light extraction efficiency together.

TABLE 1

	Volt (V)	J (mA/cm ²)	Improvement rate (%)	Improvement rate (%)	EQE	Improvement rate (%)
Organic light emitting display device 500 according to Comparative Example	7.43	10	85.41	36.1	33.07	41.6
Organic light emitting display device 300 according to example embodiment	7.55	10	100.41	45.6	39.08	50.6

As can be seen from Table 1, the organic light emitting display device 300 according to another example embodiment illustrated in FIG. 3 through FIG. 4B is improved in luminous efficiency and external quantum efficiency by 10% or more, for example, about 15%, as compared with the

organic light emitting display device 500 according to the comparative example illustrated in FIG. 5.

Meanwhile, in the organic light emitting display device 300 according to another example embodiment described with reference to FIG. 3 through FIG. 4B, the color filter 350 disposed under the overcoating layer 360 to overlap the opening 336a of the bank layer 336 is not in contact with the first electrode 341.

If the plurality of concave portions 361 is formed in the overcoating layer 360 using a negative photoresist material through photolithography or the like, as illustrated in FIG. 6, the easiest way to form the concave portions 361 of the overcoating layer 360 with good uniformity of the entire substrate is to expose bottoms 361a of the concave portions 361. Herein, if the bottoms 361a of the concave portions 361 are exposed, the color filter 350 is also exposed. Thus, there may be a big problem with the reliability of the organic light emitting diode 340. For this reason, even if the concave portions 361 of the overcoating layer 360 are satisfactory in shape, the concave portions 361 of the overcoating layer 360 may not be applied to the organic light emitting display device 300.

As illustrated in FIG. 7, in the organic light emitting display device 300 according to another example embodiment, the bottoms 361a of the plurality of concave portions 361 of the overcoating layer 360 are opened and the first electrode 341 may be in contact with the color filter 350 through the opened concave portions 361.

Therefore, if the plurality of concave portions 361 is formed in the overcoating layer 360 using a negative photoresist material through photolithography or the like, the concave portions 361 of the overcoating layer 360 are formed with high uniformity over the entire substrate, and the pattern layer 337 is on the concave portions 361 of the overcoating layer 360 so that a non-effective emission area is formed. Thus, the reliability of the organic light emitting diode 340 can be maintained.

FIG. 8A through FIG. 8C are diagrams comparatively illustrating an external light extraction efficiency and a distribution (view angle) depending on a location of an emission surface of an organic emission layer (adjustment of an effective emission area) with an adjusted thickness of a pattern layer disposed on a concave portion of an overcoating layer.

Presuming that a height from the bottom of the concave portion 361 of the overcoating layer 360 to the top of the first connection portion 362 is "H", the organic emission layer 342 is divided into four equal parts from the bottom of the concave portion 361, as illustrated in FIG. 8A, and an external light extraction efficiency and a distribution (view angle) depending on a location of an emission surface of the organic emission layer 342 (adjustment of an effective emission area) are compared using a general simulation tool at each location between the bottom of the concave portion 361 and 1H/4 (Part 1), between 1H/4 and 2H/4 (Part 2), between 2H/4 and 3H/4 (Part 3), and between 3H/4 and H (Part 4). Meanwhile, a general organic light emitting display device in which a micro lens array structure is not applied to the overcoating layer 360 and the organic light emitting diode 340 is set as a reference Ref.

As illustrated in FIG. 8B and FIG. 8C, it can be seen that at each location between the bottom of the concave portion 361 and 1H/4 (Part 1), between 1H/4 and 2H/4 (Part 2), between 2H/4 and 3H/4 (Part 3), and between 3H/4 and H (Part 4) illustrated in FIG. 8A, a front-side light extraction efficiency of the organic emission layer 343 is greatly increased from Part 1 to Part 4 due to the micro lens array

structure. Particularly, it can be seen that the front-side light extraction efficiency of Part 3 and Part 4 is improved by 30% to 40% as compared with that of the reference Ref.

Therefore, presuming that the height from the bottom of the concave portion 361 of the overcoating layer 360 to the top of the first connection portion 362 is "H", the top surface of the pattern layer 337 may be located between the bottom of the concave portion 361 and $2H/4$. Because the top surface of the pattern layer 337 is located between the bottom of the concave portion 361 and $2H/4$, the effective emission area A may be formed from the bottom of the concave portion 361 and $2H/4$ to H. Thus, the front-side light extraction efficiency can be maximized.

FIG. 9 is a cross-sectional view provided to explain an organic light emitting display device including an overcoating layer having a plurality of convex portions according to yet another example embodiment.

In FIG. 9, an organic light emitting display device 600 according to yet another example embodiment is substantially the same as the organic light emitting display device 300 illustrated in FIG. 4A and FIG. 4B except that an overcoating layer 660 includes a plurality of convex portions 663 and a pattern layer 637 is disposed on a second connection portion 664 between the plurality of convex portions 663, and, thus, the redundant description thereof will be omitted. Other elements of the organic light emitting display device 600 that are not illustrated in FIG. 9 may be identical to the elements of the organic light emitting display device 300 according to another example embodiment described with reference to FIG. 3.

The overcoating layer 660 includes the plurality of convex portions 663 formed to overlap a color filter 650 and the second connection portion 664 that connects the convex portions 663 adjacent to each other. In other words, the overcoating layer 660 includes the plurality of convex portions 663 overlap the opening 336a of the bank layer 336 illustrated in FIG. 3 and a plurality of second connection portions 664 each connecting the convex portions 663.

A first electrode 641 is disposed on the overcoating layer 660. A pattern layer 637 is disposed on the overcoating layer 660 and the first electrode 641, and an organic emission layer 642 and a second electrode 643 are disposed on the first electrode 641 and the pattern layer 637. The first electrode 641, the organic emission layer 642, and the second electrode 643 constitute an organic light emitting diode 640. The pattern layer 637 may be located on all or some of the plurality of second connection portions 664.

Because the pattern layer 637 is located on all or some of the plurality of second connection portions 664, the pattern layer 637 is disposed between the first electrode 641 and the organic emission layer 642 and the second electrode 642 in a non-effective emission area in the same manner as the pattern layer 337 located on the concave portion 361 described with reference to FIG. 1 through FIG. 8 so that a light cannot be emitted. Thus, it is possible to minimize or suppress most of the light from being confined in the organic light emitting diode 640 without a contribution to improvement of light extraction efficiency in the non-effective emission area. Further, it is possible to minimize or suppress lights confined in the organic light emitting diode 640 from remaining as light leakage components in the non-effective emission area B. Accordingly, the external light extraction efficiency of the organic light emitting diode 640 can be maximized.

FIG. 10 is a schematic system configuration view of an organic light emitting display device according to the present example embodiments.

With reference to FIG. 10, an organic light emitting display device 700 according to the present example embodiments includes an organic light emitting display panel 710 in which a plurality of data lines DL and a plurality of gate lines GL are disposed and a plurality of subpixels SP is disposed in a matrix, a data driver 720 configured to drive the plurality of data lines by supplying a data voltage to the plurality of data lines, a gate driver 730 configured to sequentially drive the plurality of gate lines GL by sequentially supplying a scan signal to the plurality of gate lines, and a controller 740 configured to control the data driver 720 and the gate driver 730. Each of a plurality of pixels disposed in the organic light emitting display panel 710 according to the present example embodiments includes the thin-film transistor and the organic light emitting diode described above with reference to FIG. 1 through FIG. 9.

According to the above-described example embodiments, the organic light emitting display device can improve external luminous efficiency and also reduce power consumption.

Further, according to the above-described example embodiments, the organic light emitting display device can improve the shape uniformity of bends of the overcoating layer that improve external luminous efficiency and also maintain the reliability of the device.

It will be apparent to those skilled in the art that various modifications and variations can be made in the organic light emitting display device of the present invention without departing from the spirit or scope of the invention. Thus, it is intended that the present invention cover the modifications and variations of this invention provided they come within the scope of the appended claims and their equivalents.

What is claimed is:

1. An organic light emitting display device, comprising: a substrate including a plurality of pixel areas having an emission area; a thin film transistor provided in each of the plurality of pixel areas; an overcoat layer covering the thin film transistor and including a plurality of concave portions and a plurality of convex portions provided on the emission area; a first electrode including concave portions and convex portions arranged on the concave portions and the convex portions of the overcoat layer to be electrically connected to the thin film transistor; a pattern layer disposed in the concave portions of the first electrode; an organic emission layer disposed on the convex portions of the first electrode and the pattern layer; and a second electrode disposed on the organic emission layer, wherein each of the organic emission layer and the second electrode on the emission area comprise a flat surface disposed on the pattern layer and convex portions disposed on the convex portions of the first electrode.
2. The organic light emitting display device according to claim 1, wherein an upper surface of the pattern layer in contact with the organic emission layer is planar.
3. The organic light emitting display device according to claim 1, further comprising: a bank layer disposed on the overcoating layer and the first electrode to separate the plurality of pixel areas, the bank layer including an opening through which the first electrode on the emission area is exposed, and wherein the pattern layer includes a same material as the bank layer.
4. The organic light emitting display device according to claim 2, wherein a height from a bottom of the concave portion of the overcoating layer to a top of the convex

13

portion of the overcoating layer is H, and wherein a flat surface of the pattern layer is located between the bottom of the concave portion and $2H/4$.

5. The organic light emitting display device according to claim 1, further comprising:

- a bank layer disposed on the overcoating layer and the first electrode to separate the plurality of pixel areas, the bank layer including an opening through which the first electrode on the emission area is exposed, and
- a color filter disposed under the overcoating layer to overlap the opening of the bank layer.

6. The organic light emitting display device according to claim 5, wherein each of a bottom of the concave portions of the overcoating layer is opened to expose a portion of the color filter, and

- wherein each of the concave portions of the first electrode is contacted with the color filter exposed between the concave portions of the overcoat layer.

7. The organic light emitting display device according to claim 1, wherein a thickness of the organic emission layer disposed between the concave portion and the convex portion of the first electrode is less than a thickness of the organic emission layer disposed at a bottom of the concave portion or a top of the convex portion of the first electrode.

8. The organic light emitting display device according to claim 1, wherein the emission area of each of the plurality of pixel areas includes:

- an effective emission area having a convex surface shape; and
- a non-effective emission area disposed between the effective emission areas and having a flat surface shape.

9. The organic light emitting display device according to claim 1, further comprising a passivation layer disposed between the overcoat layer and the first electrode.

10. An organic light emitting display device, comprising: a plurality of pixels disposed on a substrate and including an emission area;

- wherein each of the plurality of pixels includes: an effective emission area having a convex surface shape; and

- a non-effective emission area disposed between the effective emission areas and having a flat surface shape.

11. The organic light emitting display device according to claim 10, wherein the non-effective emission area includes:

- a first electrode including concave portions;
- a pattern layer disposed in concave portions of the first electrode;
- an organic emission layer disposed on the pattern layer; and
- a second electrode disposed on the organic emission layer.

12. The organic light emitting display device according to claim 10, further comprising:

- a first electrode disposed on the emission area;
- an organic emission layer disposed on the first electrode;
- a second electrode disposed on the organic emission layer; and
- a pattern layer disposed between the first electrode on the non-effective emission area and the organic emission layer,

wherein the first electrode includes a plurality of convex portions convexly disposed on the effective emission area and a plurality of concave portions concavely disposed on the non-effective emission area, and wherein the organic emission layer and the second electrode include a plurality of convex portions convexly

14

disposed on the effective emission area and a plurality of flat surfaces flatly disposed on the non-effective emission area.

13. The organic light emitting display device according to claim 11, wherein the pattern layer is disposed in the concave portions of the first electrode and an upper surface of the pattern layer in contact with the organic emission layer is planar.

14. The organic light emitting display device according to claim 13, wherein the pattern layer is filled in all or some of each of the concave portions of the first electrode.

15. An organic light emitting display device, comprising: a plurality of pixels disposed on a substrate and including an emission area;

- wherein each of the plurality of pixels includes: a first electrode disposed on the emission area; an organic emission layer disposed on the first electrode; a second electrode disposed on the organic emission layer; and

- a color filter disposed on a substrate and overlapped with the first electrode,

wherein the organic emission layer includes: an effective emission area having a convex surface shape; and

- a non-effective emission area disposed between the effective emission areas and having a flat surface shape.

16. The organic light emitting display device according to claim 15, wherein the first electrode is directly contacted to the color filter in the non-effective emission area.

17. The organic light emitting display device according to claim 15, wherein the first electrode includes a plurality of convex portions convexly disposed on the effective emission area and a plurality of concave portions concavely disposed on the non-effective emission area, and

- wherein each of the plurality of pixels further includes a pattern layer interposed between the concave portion of the first electrode and the organic emission layer in the non-effective emission area.

18. The organic light emitting display device according to claim 15, wherein each of the plurality of pixels further includes a pattern layer interposed between the first electrode and the organic emission layer in the non-effective emission area,

- wherein the first electrode includes a plurality of convex portions convexly disposed on the effective emission area and a plurality of concave portions concavely disposed on the non-effective emission area, and
- wherein the organic emission layer and the second electrode include a plurality of convex portions convexly disposed on the effective emission area and a plurality of flat surfaces flatly disposed on the non-effective emission area.

19. The organic light emitting display device according to claim 18, wherein a thickness of the organic emission layer disposed between the concave portion and the convex portion of the first electrode is less than a thickness of the organic emission layer disposed at a bottom of the concave portion or a top of the convex portion of the first electrode.

20. The organic light emitting display device according to claim 17, wherein the pattern layer is disposed in the concave portions of the first electrode and an upper surface of the pattern layer in contact with the organic emission layer is planar.

21. The organic light emitting display device according to claim 20, wherein the pattern layer is filled in all or some of each of the concave portions of the first electrode.

专利名称(译)	有机发光显示装置		
公开(公告)号	US10319796	公开(公告)日	2019-06-11
申请号	US15/968594	申请日	2018-05-01
[标]申请(专利权)人(译)	乐金显示有限公司		
申请(专利权)人(译)	LG DISPLAY CO. , LTD.		
当前申请(专利权)人(译)	LG DISPLAY CO. , LTD.		
[标]发明人	JANG JIHYANG KIM SOOKANG JO SOYOUNG KOO WONHOE LIM HYUNSOO CHOI MINGEUN		
发明人	JANG, JIHYANG KIM, SOOKANG JO, SOYOUNG KOO, WONHOE LIM, HYUNSOO CHOI, MINGEUN		
IPC分类号	H01L27/32 H01L51/52		
CPC分类号	H01L27/3246 H01L27/322 H01L27/326 H01L27/3258 H01L51/5209 H01L51/5225 H01L51/5275 H01L27/3272 H01L2251/5315 H01L51/5262		
优先权	1020150134419 2015-09-23 KR		
其他公开文献	US20180247987A1		
外部链接	Espacenet		

摘要(译)

有机发光显示装置包括在基板上的外涂层;外涂层上的第一电极;外涂层和第一电极上的堤层,堤层包括开口,第一电极通过该开口露出;在第一电极的暴露部分上具有岛状的图案层;第一电极和图案层上的有机发光层;和有机发射层上的第二电极。

